

**YODOCK TRAFFIC CONTROL DEVICE
350 RAIL ATTACHMENT
SPECIFICATIONS**

INTENT: IT IS THE INTENT OF THIS SPECIFICATION TO DESCRIBE A STEEL RAIL ATTACHMENT USE TO MAKE A PORTABLE PLASTIC ENERGY DISPERSEMENT CELL MEET THE NCHRP 350 REQUIREMENTS FOR LONGITUDINAL BARRIER WALL. THE 350 RAIL ATTACHMENT IS INTENDED TO BE USED IN CONJUNCTION WITH THE YODOCK MODEL 2001 AND 2001M IN THE PREVENTION OF VEHICULAR PENETRATION OF A WORK ZONE.

SCOPE: THIS SPECIFICATION RECOGNIZES THE NEED FOR A 350 RAIL ATTACHMENT USED WITH A PORTABLE ENERGY DISPERSEMENT CELL TO PERFORM SOME OF THE FUNCTIONS OF CONCRETE BARRIERS USED TO CONTROL, DIRECT, CHANNEL AND STOP VEHICULAR TRAFFIC FOR PURPOSES OF AIDING IN CONTAINMENT AND/OR SAFETY.

CONSTRUCTION: THE 350 RAIL ATTACHMENT IS MADE OF STEEL AND WOOD. IT IS MANUFACTURED TO RESIST COOROSION AND WITHSTAND THE IMPACT OF VEHICULAR TRAFFIC. THE 350 RAIL ATTACHMENT IS MOUNTED TO THE YODOCK TRAFFIC CONTROL SYSTEM MODELS 2001 AND 2001M. IT IS COMPRISED OF TWO TUBULAR STEEL BOX BEAM RAILS, WHICH ARE BOLTED TO TWO STEEL BRACKETS WHICH ARE PLACED WITHIN THE FORK LIFT HOLES OF THE MODEL 2001 AND 2001M. THE BOX BEAM RAILS ARE BLOCKED AWAY FROM THE STEEL BRACKETS USING WOOD BLOCKS. THE RAIL SEGMENTS ARE BOLTED TO THE STEEL BRACKETS WITH GRADE 5 CARRIAGE BOLTS. ADJACENT RAILS ARE SPLICED TOGETHER USING SPLICE TUBES AND BOLTED TOGETHER USING GRADE 8 HEX HEAD BOLTS.

BOX BEAM: 1830mm, 89X89X6.4 mm

BOX BEAM CONNECTION BOLTS: 19 mm diameter x 230 mm long, grade 5 carriage

SPLICE TUBE BOLTS: 19 mm diameter x 114 mm long, grade 8 hex

BOX BEAM FUNCTIONAL LENGTH: 1830 mm

SPLICE TUBES: 280 mm, 64X64X6.4 mm

WOOD BLOCKS: 102X102X254 mm

STEEL BRACKETS: C10X15.3

MATERIAL: **RAILS:** A500 GRADE B TUBULAR STEEL
 BRACKETS: A36 CHANNEL STEEL
 SPACERS: WOOD
 CARRIAGE BOLTS: GRADE 5
 HEX HEAD BOLTS: GRADE 8

INSTALLATION: EACH RAIL ATTACHMENT SHALL WEIGH APPROXIMATLY 200 POUNDS. WHEN INSTALLED ON THE MODEL 2001 OR 2001M, THE RAIL ATTACHMENT SHALL BE INTERLOCKED TO FORM A CONTINOUS STRUCTURE. THE INSTALLED 2001 OR 2001M WITH 350 RAILS ATTACHMENT MUST BE TERMINATED WITH AN APPROVED METHOD SUCH AS AN ENDTREATMENT OR A TAPER. BOTH THE MODEL 2001 AND 2001M WITH RAIL ATTACHMENTS MUST BE USED IN ACCORDENANCE WITH USERS MANUAL. THE MODEL 2001 WITH RAIL ATTACHMENT HAS MET THE REQUIREMENTS OF NCHRP 350 TL-3. THE MODEL 2001M WITH RAIL ATTACHMENT HAS MET THE NCHRP 350 TL-2 REQUIREMENTS. BOTH MODELS WITH RAIL ATTACHMENTS HAVE BEEN APPROVED BY THE FEDERAL HIGHWAY ADMINISTRATION FOR USE, SEE FHWA APPROVAL LETTER B97.

25 BARRIERS
150' (45.72m)

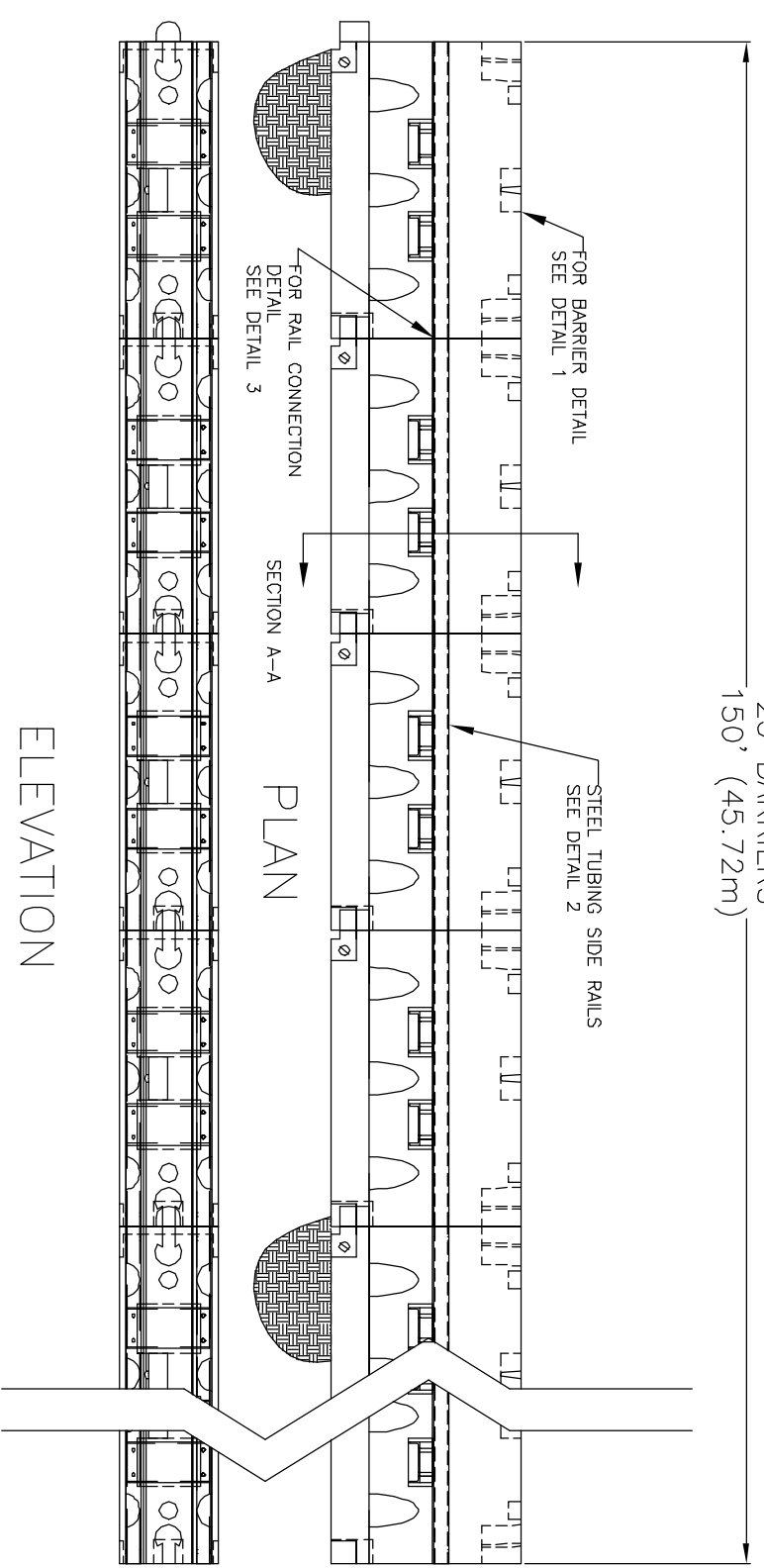

ELEVATION

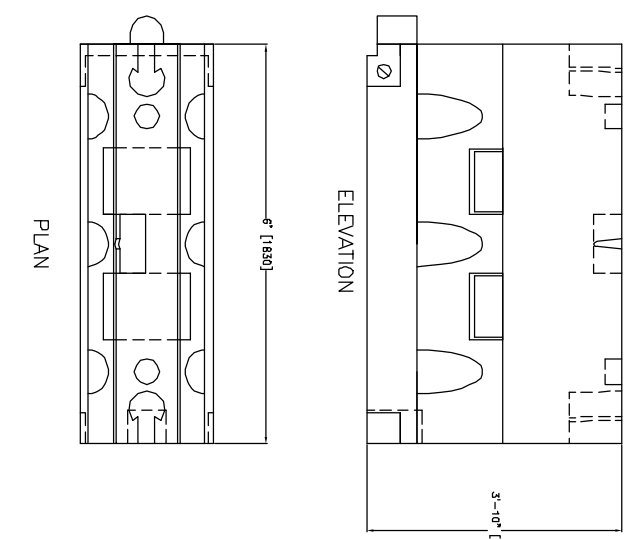
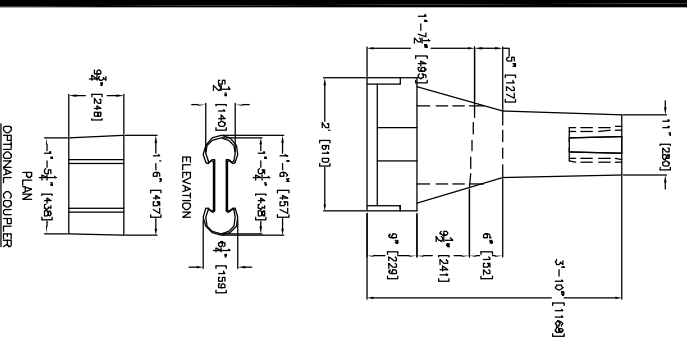

ELEVATION

PLAN

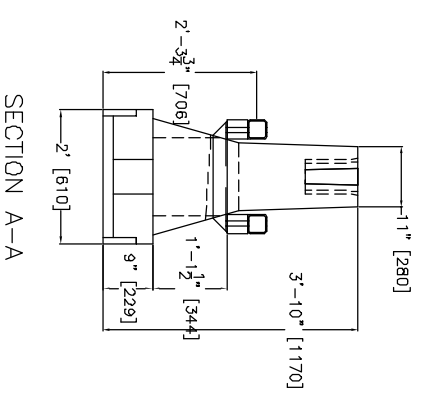

SECTION A-A

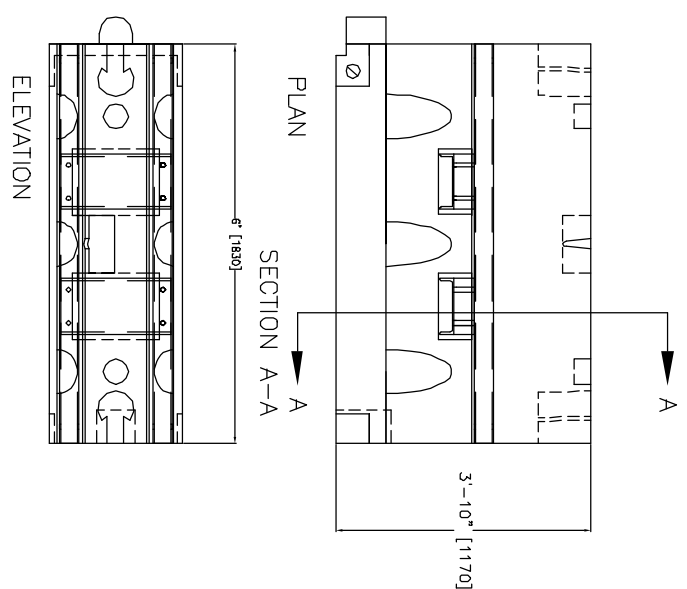

ELEVATION

PLAN

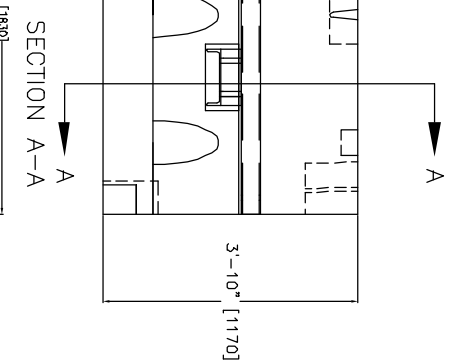

SECTION A-A

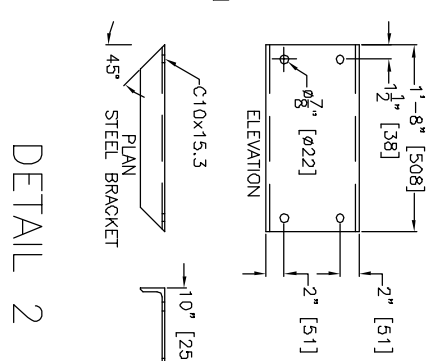
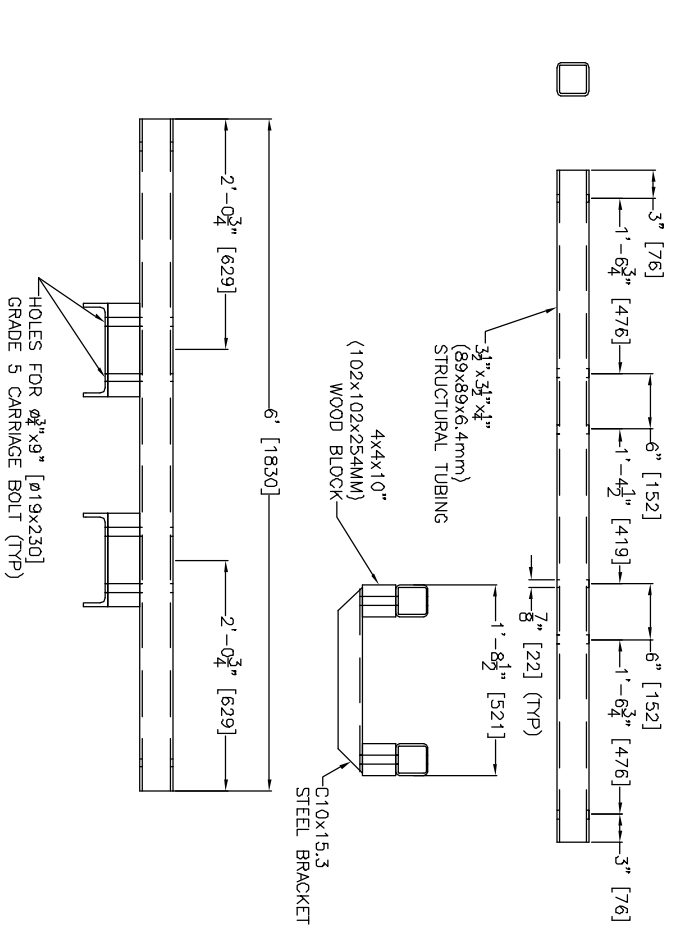

DETAIL 2

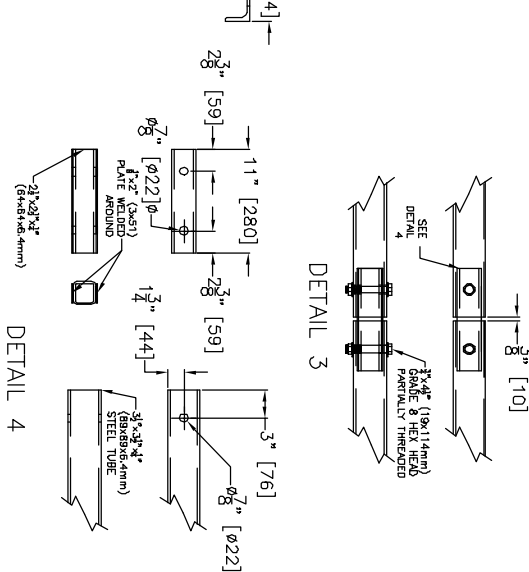

DETAIL 3

THE YODOCK WALL COMPANY INC.

Revisions

No	Date	By	Title
1.			The Yodock Traffic Control System: Longitudinal barrier
2.			
3.			
4.			
5.			

Project No. 400001-RWC
Date 8/01
Drawn By BAS
Scale
Title Yodock model 2001 with rail attachment
Sheet No. 1 of 1